



PERFORMANCE RANGE

- Flow rate up to **120 l/min** (7.2 m³/h)
- Head up to **105 m**

APPLICATION LIMITS

- Manometric suction lift up to **7 m**
- Maximum liquid temperature **+40 °C**
- Max. working pressure **10 bar**
- Continuous service **S1**

CONSTRUCTION AND SAFETY STANDARDS

Complete with **2 m** long power cable

EN 60335-1
IEC 60335-1
CEI 61-150

EN 60034-1
IEC 60034-1
CEI 2-3



INSTALLATION AND USE

Suitable for use with clean water and liquids that are not chemically aggressive towards the materials from which the pump is made. As a result of their reliability and quietness they are suitable for use in domestic and civil applications where there is a lack of ventilation or space as well as in wet environments, etc.

They are capable of functioning at depths of up to 20 m provided that they are equipped with a sufficiently long power cable.

OPTIONALS AVAILABLE ON REQUEST

- Other voltages or 60 Hz frequency

GUARANTEE

1 year subject to terms and conditions

CERTIFICATIONS



CHARACTERISTIC CURVES AND PERFORMANCE DATA

50 Hz n= 2900 1/min HS= 0 m

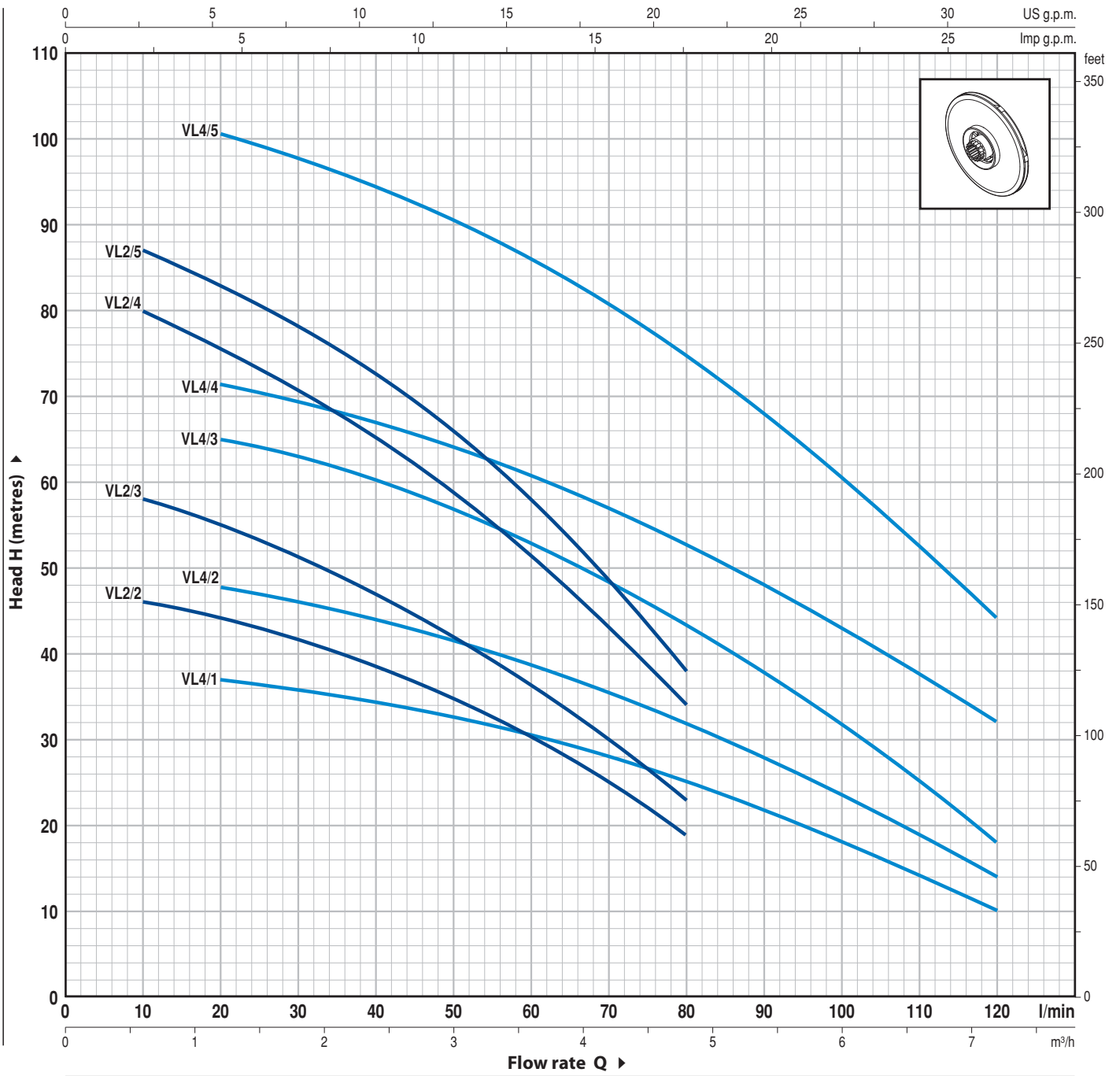

MODEL		POWER		Q	Flow rate												
Single-phase	Three-phase	kW	HP		m³/h	0	0.6	1.2	1.8	2.4	3.0	3.6	4.2	4.8	5.4	6.0	6.6
				l/min	0	10	20	30	40	50	60	70	80	90	100	110	120
VLm 2/2	-	0.55	0.75	H metres	48	46	44	41.5	39	35	30	25	19				
VLm 2/3	VL 2/3	0.75	1		60	58	55	51	47	42	36	30	23				
VLm 2/4	VL 2/4	1.1	1.5		84	80	75	70	65	59	51	42.5	34				
VLm 2/5	VL 2/5	1.5	2		90	87	83	78	73	66	58	48	38				
VLm 4/1	-	0.55	0.75		40	-	37	36	34.5	32.5	30	28	25	21.5	18.5	14.5	10
VLm 4/2	VL 4/2	0.75	1		50	-	48	46	44	41	38	35	32	28	24	19	14
VLm 4/3	VL 4/3	1.1	1.5		67	-	65	62.5	60	56.5	52	48	44	38	32	25	18
VLm 4/4	VL 4/4	1.5	2		75	-	72	69	66	64	60	57	53	48	43	38	32
VLm 4/5	VL 4/5	2.2	3		105	-	101	98	94	90	86	80	75	67	60	52	44

Q = Flow rate H = Total manometric head

Tolerance of characteristic curves in compliance with EN ISO 9906 App. A.

POS.	COMPONENT	CONSTRUCTION CHARACTERISTICS				
1	SUCTION BODY	Stainless steel AISI 304, complete with threaded suction port in compliance with ISO 228/1				
2	EXTERNAL SLEEVE	Stainless steel AISI 304, complete with threaded delivery port in compliance with ISO 228/1				
3	MOTOR SLEEVE	Stainless steel AISI 304				
4	IMPELLERS AND DIFFUSERS	Noryl GFN2V				
5	DIAPHRAGMS	Stainless steel AISI 304, complete with anti-wear ring				
6	MOTOR SHAFT	Stainless steel EN 10088-3 - 1.4104				
7	TWO MECHANICAL SEALS SEPARATED BY AN OIL CHAMBER					
	<i>Seal</i>	<i>Shaft</i>	<i>Position</i>	<i>Materials</i>		
	<i>Model</i>	<i>Diameter</i>		<i>Stationary ring</i>	<i>Rotational ring</i>	<i>Elastomer</i>
	MG1-16	Ø 16 mm	Motor side	Silicon carbide	Graphite	NBR
	MG1-15 SIC	Ø 15 mm	Pump side	Silicon carbide	Silicon carbide	NBR
8	BEARINGS	6303 2RS - C3 / 6203 ZZ - C3				
9	CAPACITOR					
	<i>Pump</i>	<i>Capacitance</i>				
	<i>Single-phase</i>	(230 V or 240 V)	(110 V)			
	VLm 2/2	16 µF 500 VL	30 µF 250 VL			
	VLm 4/1					
	VLm 2/3	20 µF 500 VL	-			
	VLm 4/2					
	VLm 2/4	25 µF 500 VL	-			
	VLm 4/3					
10	ELECTRIC MOTOR					
	VLm: single-phase 230 V - 50 Hz with built-in overload protector.					
	VL: three-phase 400 V - 50 Hz.					
	- Insulation: F class.					
	- Protection: IP 68.					
11	POWER CABLE					
	2 metre long "H07 RN-F" cable					

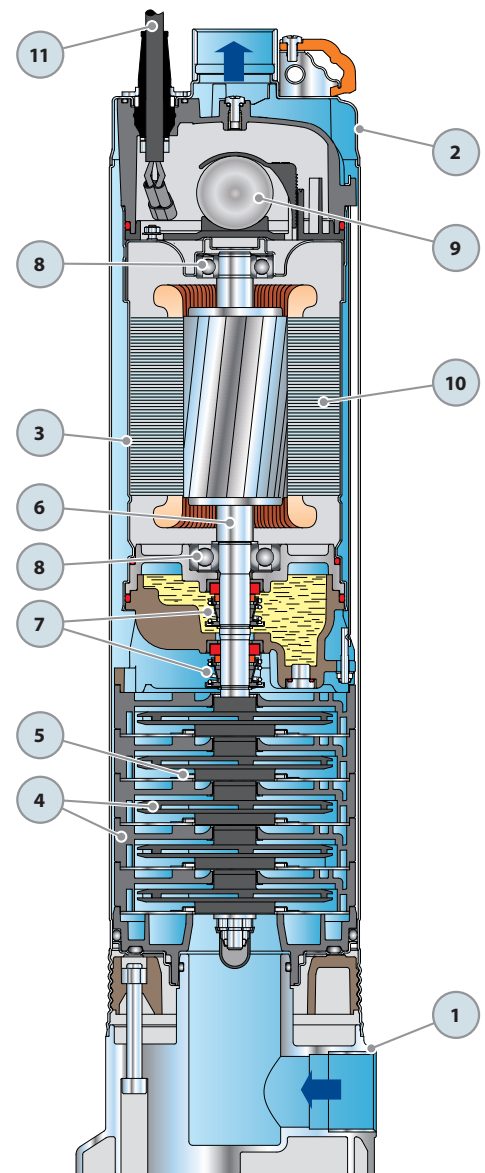

DIMENSIONS AND WEIGHT

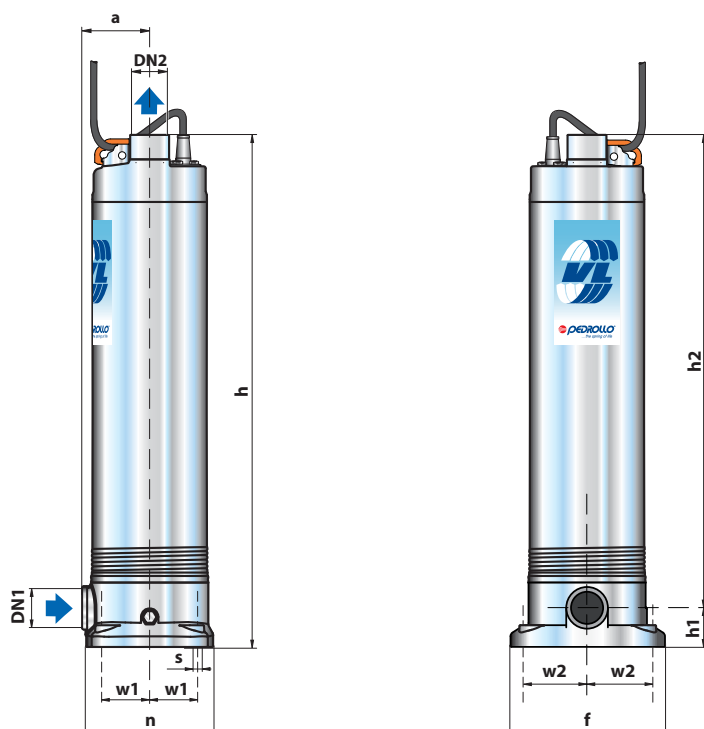

MODEL		PORTS		N° STAGES	DIMENSIONS mm									kg			
Single-phase	Three-phase	DN1	DN2		a	f	h	h1	h2	n	w1	w2	s	1~	3~		
VLm 2/2 VLm 4/1	-	1 1/4"	1 1/4"	4	74	166	565	45	520	146	52.5	62.5	11	15.0	-		
VLm 2/3 VLm 4/2	-			5			618		573							18.0	-
-	VL 2/3 VL 4/2			5			588		543								
VLm 2/4 VLm 4/3	VL 2/4 VL 4/3			7			665		620							20.1	18.9

ABSORPTION

MODEL	VOLTAGE (single-phase)		
	230 V	240 V	110 V
Single-phase	230 V	240 V	110 V
VLm 2/2	5.0 A	5.0 A	10.0 A
VLm 2/3	6.0 A	6.0 A	-
VLm 2/4	7.5 A	7.5 A	-
VLm 4/1	5.0 A	5.0 A	10.0 A
VLm 4/2	6.0 A	6.0 A	-
VLm 4/3	7.5 A	7.5 A	-

MODEL	VOLTAGE (three-phase)			
	230 V	400 V	240 V	415 V
Three-phase	230 V	400 V	240 V	415 V
VL 2/3	4.5 A	2.6 A	4.5 A	2.6 A
VL 2/4	5.2 A	3.0 A	5.2 A	3.0 A
VL 4/2	4.5 A	2.6 A	4.5 A	2.6 A
VL 4/3	5.2 A	3.0 A	5.2 A	3.0 A

PALLETIZATION

MODEL		GROUPAGE				CONTAINER			
Single-phase	Three-phase	n° pumps	H (mm)	kg		n° pumps	H (mm)	kg	
				1~	3~			1~	3~
VLm 2/2 VLm 4/1	-	25	869	361	-	40	1307	615	-
VLm 2/3 VLm 4/2	-	25	869	468	-	40	1307	738	-
-	VL 2/3 VL 4/2	25	869	-	432	40	1307	-	681
VLm 2/4 VLm 4/3	VL 2/4 VL 4/3	25	869	518	488	40	1307	819	771

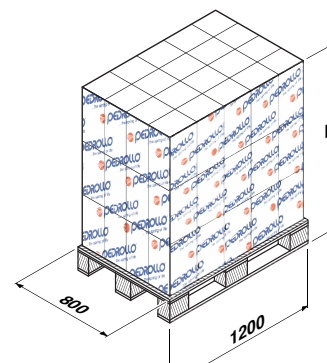

POS.	COMPONENT	CONSTRUCTION CHARACTERISTICS				
1	SUCTION BODY	Stainless steel AISI 304, complete with threaded suction port in compliance with ISO 228/1				
2	EXTERNAL SLEEVE	Stainless steel AISI 304, complete with threaded delivery port in compliance with ISO 228/1				
3	MOTOR SLEEVE	Stainless steel AISI 304				
4	IMPELLERS AND DIFFUSERS	Noryl GFN2V				
5	DIAPHRAGMS	Stainless steel AISI 304, complete with anti-wear ring				
6	MOTOR SHAFT	Stainless steel EN 10088-3 - 1.4104				
7	TWO MECHANICAL SEALS SEPARATED BY AN OIL CHAMBER					
	Seal	Shaft	Position	Materials		
	<i>Model</i>	<i>Diameter</i>		<i>Stationary ring</i>	<i>Rotational ring</i>	<i>Elastomer</i>
	MG1-19	Ø 19 mm	Motor side	Silicon carbide	Graphite	NBR
	MG1-18 SIC	Ø 18 mm	Pump side	Silicon carbide	Silicon carbide	NBR
8	BEARINGS	6304 2RS - C3 / 6203 ZZ - C3				
9	CAPACITOR					
	Pump	Capacitance				
	<i>Single-phase</i>	<i>(230 V or 240 V)</i>				
	VLm 2/5	35 µF 450 VL				
	VLm 4/4	50 µF 450 VL				
	VLm 4/5	50 µF 450 VL				
10	ELECTRIC MOTOR					
	VLm: single-phase 230 V - 50 Hz.		Windings up to 1.5 kW with built-in thermal overload protector.			
			➡ The VLm4/5 2.2 kW pump is equipped with an external manual reset overload protector housed in the control box.			
	VL: three-phase 400 V - 50 Hz.		– Insulation: F class.			
			– Protection: IP 68.			
11	POWER CABLE					
	2 metre long "H07 RN-F" cable with removable connector					
12	CONTROL BOX (for single-phase versions only)					
	Complete with capacitor and power cable with Schuko plug					

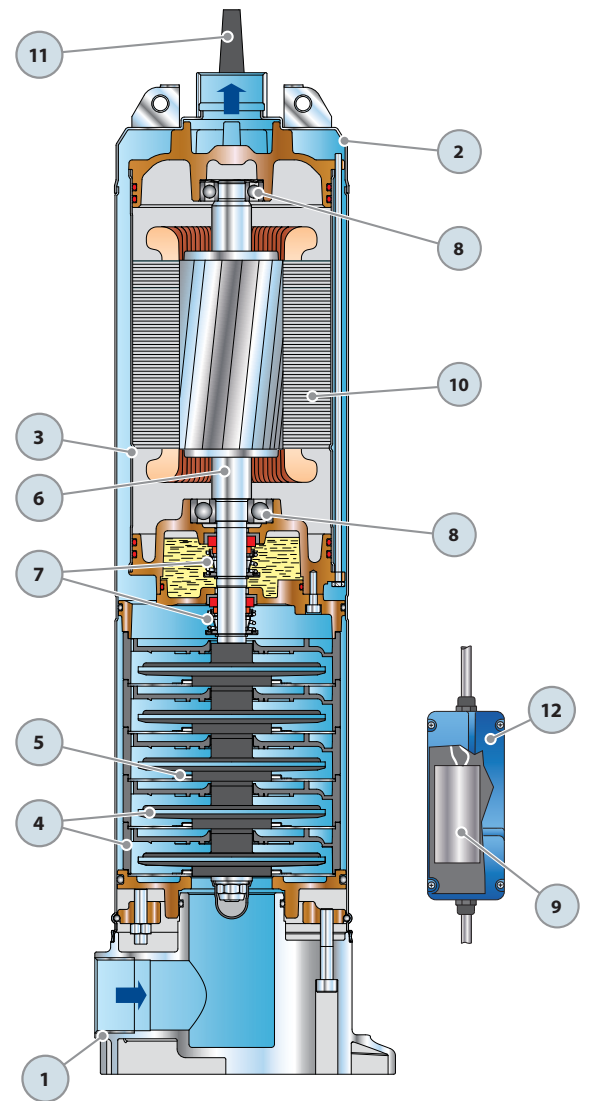

DIMENSIONS AND WEIGHT

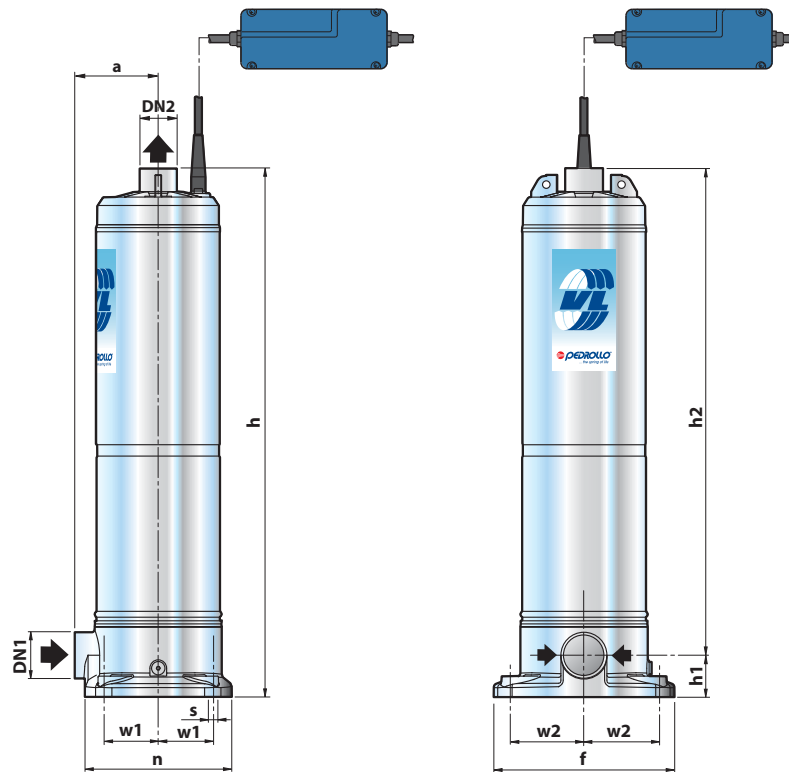

MODEL		PORTS		N° STAGES	DIMENSIONS mm									kg	
Single-phase	Three-phase	DN1	DN2		a	f	h	h1	h2	n	w1	w2	s	1~	3~
VLm 2/5	VL 2/5	1½"	1¼"	6	100	223	663	50	613	183	62	88.5	11	31.7	28.8
VLm 4/4	VL 4/4			5	633		583		31.0					29.4	
VLm 4/5	VL 4/5			7	693		643		35.5					33.0	

ABSORPTION

MODEL	VOLTAGE (single-phase)	
Single-phase	230 V	240 V
VLm 2/5	9.0 A	9.0 A
VLm 4/4	9.5 A	9.5 A
VLm 4/5	14.0 A	14.0 A

MODEL	VOLTAGE (three-phase)			
Three-phase	230 V	400 V	240 V	415 V
VL 2/5	6.2 A	3.6 A	6.2 A	3.6 A
VL 4/4	6.2 A	3.6 A	6.2 A	3.6 A
VL 4/5	8.5 A	4.9 A	8.5 A	4.9 A

PALLETIZATION

MODEL		GROUPAGE				CONTAINER			
Single-phase	Three-phase	n° pumps	H (mm)	kg		n° pumps	H (mm)	kg	
				1~	3~			1~	3~
VLm 2/5	VL 2/5	25	1340	809	737	40	2060	1285	1169
VLm 4/4	VL 4/4	25	1340	792	752	40	2060	1258	1193
VLm 4/5	VL 4/5	25	1340	905	841	40	2060	1437	1336

