

DGBOX

ELECTRONIC PUMP CONTROLLER

- **Three sizes**
 - 30 = 3,0 Kw
 - 55 = 5,5 Kw
 - 75 = 7,5 Kw
- **Booster set** or single pump
- **Variable speed** and Fixed speed

Ready to Plug & Play



Complete with:

- Cabinet
- Main switch disconnecter
- Line protection

- **IP65 enclosure**

Suitable for tough environments

FLEXIBLE

HIGH PERFORMANCE

EASY TO USE



DG FLOW

YOUR WATER UNDER CONTROL

FLEXIBLE

To meet the need of managing combinations of

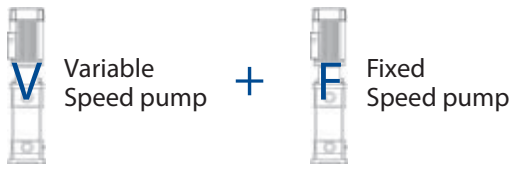

DGBOX models:

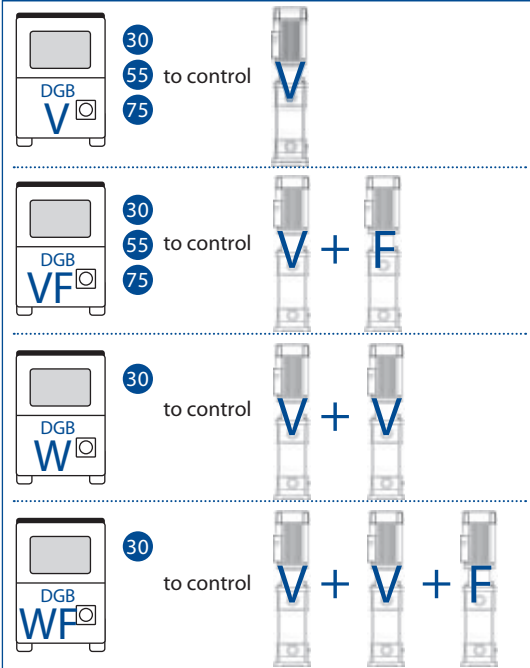

Ready to Plug & Play

Application examples:

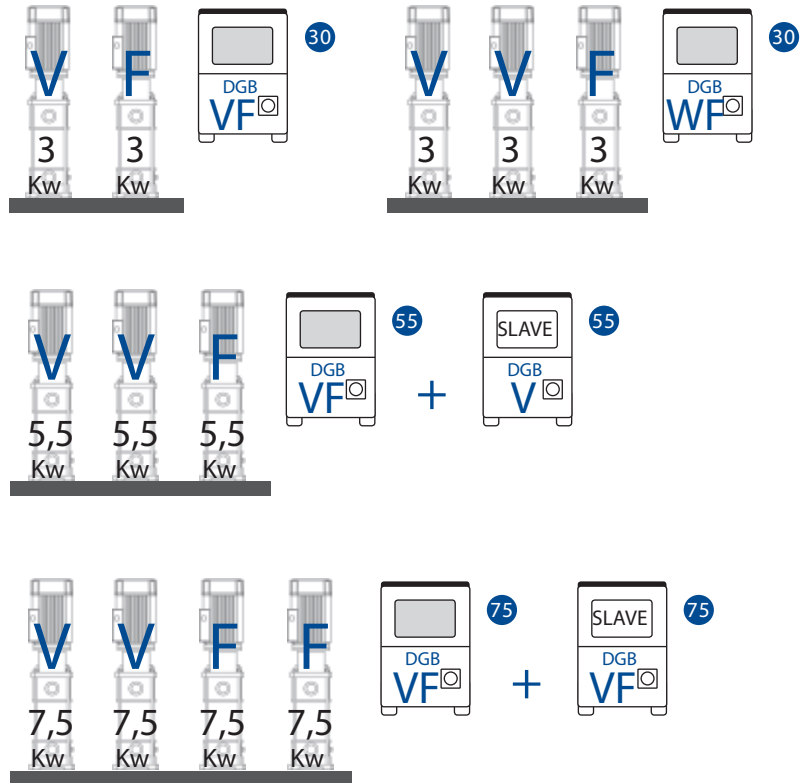

Equivalent slave models allows the control of additional pumps using the main unit interface

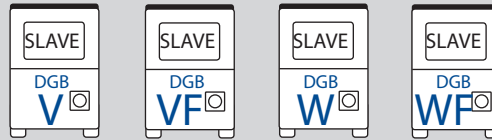

PERFORMANCE

The double fan forced cooling system combined with the IP 65 cabinet allow the usage of DGBOX even with ambient temperatures up to 40°C. DGBOX is equipped with built-in electronic filter to meet EMC requirements.



EASY TO USE

A backlit graphic LCD makes configuration and usage simple and safe.



Power and signal electrical connections are safe and easy thanks to the wide separate compartment and quick connectors.

